

Winnebago County Planning and Zoning Department

NOTICE OF PUBLIC HEARING BOARD OF ADJUSTMENT 3/30/2021

TO WHOM IT MAY CONCERN:

The applicant(s) listed below has requested a variance which is regulated by one or more of the following ordinances: Chapter 23, the Town/County Zoning Code, Chapter 26, the Floodplain Zoning Code, and Chapter 27, the Shoreland Zoning Code. You are receiving this notice because this application or petition for action: 1. affects area in the immediate vicinity of property which you own; 2. requires your agency to be notified; 3. requires your Town to be notified; or 4. requires you, as the applicant, to be notified.

The Winnebago County Board of Adjustment will be holding a public hearing on 3/30/2021 at 5:30 p.m. in Conference Room 120 of the County Administration Building located at 112 Otter Ave, Oshkosh, WI.

Meetings will be held via Zoom for the welfare of everyone involved. All interested persons wishing to be heard at the public hearing may appear in person however we are encouraging the public to stay home and stay safe.

Join Zoom Meeting: <https://us02web.zoom.us/j/83094259247?pwd=WXhNc3NSREpLZnZrQnpSQmp0cDNQZz09>

Dial by your location: +1 312 626 6799 US (Chicago)

Meeting ID: 830 9425 9247

Passcode: 603388

Additional Instructions for making a virtual appearance can be found at:

<https://www.co.winnebago.wi.us/planning-and-zoning>.

INFORMATION ON VARIANCE REQUEST

Applicant: GOLDBERG REV TST, BETH A GOLDBERG REV TST, GARY J

Agent: SMITH, CHRIS - SMITH BUILDERS

File Number: 2021-VA-5580

Location of Premises: 3693 SHANGRI-LA POINT RD

Tax Parcel No.: 018-2335

Legal Description: Being all of Lot 2 of Shangri-La Point Plat located in part of the fractional NE 1/4 of Section 5, Township 18 North, Range 16 East, Town of Oshkosh, Winnebago County, Wisconsin.

Description of Proposed Project: Applicant is requesting a variance for a sub-standard fill requirement.

<u>DESCRIPTION:</u>	<u>CODE REFERENCE:</u>	<u>REQUIRED:</u>	<u>PROPOSED:</u>
The elevation of the lowest floor shall be at or above the flood protection elevation on fill unless the requirements in subsection (b)(2) can be met. The fill shall be one foot or more above the regional flood elevation extending at least 15 feet beyond the limits of the structure.	26.5-23 (b)(1)	15 ft	5 ft & 7ft

INITIAL STAFF REPORT

Sanitation: Existing System; Municipal System

Overlays: Floodplain; Shoreland

Current or Proposed Zoning: R-2 Suburban Low Density Residential

Code Reference: 26.5-23 (b)(1)

Description of Proposed Use: Applicant is requesting a variance for a sub-standard fill requirement.

Surrounding Zoning: North: R-1; South: R-2; East: N/A; West: N/A

THE FOLLOWING INFORMATION HAS BEEN PROVIDED BY THE OWNER / APPLICANT

Describe your project, include the proposed dimensions and setbacks:

The existing home, detached garage and lakeside shed are to be removed and a new home built on the site. The new home will be built to meet minimum floodplain requirements and will rest entirely inside all setback lines, with the exception of the requirement for fill to be placed 15 ft in all directions at an elevation of 1 ft above the 100 year flood elevation. Detailed dimensions and setback requirements are shown on the attached site plan. In addition, street setback averaging has been done by Winnebago County and this lot is allowed 17' versus the typical 30'; but this proposed project is setting back even further to 22.5'.

Describe how compliance with the requirement in question unreasonably prevents or restricts development of a permitted use on the property:

The requirement to place fill around the foundation 15 feet in all directions at an elevation of 1 ft above the 100 year flood elevation will be met on the front and back of the home. Along the side lot lines the setbacks are less than the 15 foot minimum floodplain fill requirement (ten feet along the south and seven feet along the north) and to adhere to the 15 foot fill requirement would significantly reduce/restrict the buildable area on the lot.

Describe the unique physical characteristics or limitations that prevent the property from being developed in compliance with the requirement in question:

The side lot line setbacks are less than the 15 foot minimum floodplain fill requirement (ten feet along the south and seven feet along the north) and to adhere to the 15 foot floodplain fill requirement would significantly reduce/restrict the buildable area on the lot.

Describe how the granting of the requested variance will not harm the public interest or have adverse affects on surrounding properties:

The approval of this variance will allow the existing side lot drainage flow to be maintained while providing for a new home to be constructed to current floodplain guidance, replacing three structures that do not meet this current floodplain guidance on the property. The proposed retaining walls will be installed along the north and south sides to ensure existing property line drainage is maintained and will keep the fill from impacting the property to north and to the south per the attached sketches.

Retaining walls are necessary to avoid a very steep side slope that could be prone to erosion. No adverse impacts will occur to adjoining properties. In addition, the removal of the existing detached garage and lakeside shed will improve the appearance of the lake shore and road side views as the structures will no longer be in the current setback areas.

SECTION REFERENCE AND BASIS OF DECISION

Town/County Zoning Code

23.7-234 Basis of decision

When making its decision, the Board of Adjustment shall consider each of the following standards:

- (1) The requirement in question would unreasonably prevent the property owner from using the property for a permitted purpose or would render conformity with such requirement unnecessarily burdensome and such circumstances were not self-created.
- (2) The subject property has unique physical characteristics or limitations that prevent the property from being developed in compliance with the requirement in question.
- (3) The granting of the variance will not be contrary to or harm the public interest given the general purposes of the zoning regulations and the specific purposes of the requirement in question.

The board shall grant a variance only if the board can make an affirmative finding for all of the criteria listed in this section.

Floodplain Zoning Code

26.6-7 Variances

(a) **Review criteria.** The Board of Adjustment may, upon appeal, grant a variance from the standards of this chapter if an applicant convincingly demonstrates that (1) literal enforcement of this chapter will cause unnecessary hardship; (2) the hardship is due to adoption of the floodplain chapter and unique property conditions, not common to adjacent lots or premises—in such case the chapter or map must be amended—; (3) the variance is not contrary to the public interest; and (4) the variance is consistent with the purpose of this chapter in s. 26.1-5.

(b) **Additional criteria.** In addition to the criteria in subsection (a), to qualify for a variance under FEMA regulations, the following criteria must be met:

- (1) The variance shall not cause any increase in the regional flood elevation;
- (2) Variances can only be granted for lots that are less than 0.5 acres and are contiguous to existing structures constructed below the regional flood elevation;
- (3) Variances shall only be granted upon a showing of good and sufficient cause, shall be the minimum relief necessary, shall not cause increased risks to public safety or nuisances, shall not increase costs for rescue and relief efforts, and shall not be contrary to the purpose of the chapter.

(c) **Limitations.** A variance shall not (1) grant, extend, or increase any use prohibited in the zoning district; (2) be granted for a hardship based solely on an economic gain or loss; (3) be granted for a hardship which is self-created; (4) damage the rights or property values of other persons in the area; (5) allow actions without the amendments to this chapter or map(s) required in s. 26.6-4; or (6) allow any alteration of an historic structure, including its use, which would preclude its continued designation as an historic structure.

Shoreland Zoning Code

27.6 -8 Variances

(a) **Generally.** The Board of Adjustment may, upon appeal, grant a variance from the standards of this chapter if an applicant convincingly demonstrates that (1) literal enforcement of this chapter will cause unnecessary hardship; (2) the hardship is due to unique property conditions, not common to adjacent lots or premises; (3) the variance is not contrary to the public interest; and (4) the variance is consistent with the purpose of this chapter.

Floodplain Fill Variance – Additional Information Required

An additional sheet must be filed for each side of the structure where the floodplain fill requirement will not be met.

Retaining wall X OR Sloped to property line _____

Sloped to property line – Benchmark must be established by a Registered Land Surveyor

Surveyor Fox Valley Land Surveying Date (BM Established) _____

BM Elevation 749.02' BM Description Center of sanitary manhole

A. Regional Floodplain elevation 749.9

B. Required Elevation of fill (A + 1 ft) ; 752.3

Side (Circle one) N S E W

C. Lowest ground elevation along property line, in affected area 749.0

D. Depth of Fill required (B – C) 2.3

E. Length of horizontal slope using 3:1 slope (D x 3) N/A

F. Width of Swale (if proposed) N/A

G. Side yard setback proposed for structure 7'-0"

H. Total horizontal fill proposed (G – E – F) 7'-0"

Retaining Wall

Side (Circle one) N S E W

Total fill proposed (from foundation to outer edge of retaining wall) 7-15 ft

Will the retaining wall(s) meet the 75' required setback from the Ordinary High Water Mark?

YES _____ NO X

If no, variance requested for retaining wall? 10 ft

List any measures proposed to prevent run-off onto neighboring properties:

 X Swale _____ Drain Tile X Downspouts to lake/ditch

_____ Other:

Floodplain Fill Variance – Additional Information Required

An additional sheet must be filed for each side of the structure where the floodplain fill requirement will not be met.

Retaining wall X **OR** Sloped to property line _____

Sloped to property line – Benchmark must be established by a Registered Land Surveyor

Surveyor Fox Valley Land Surveying Date (BM Established) _____

BM Elevation 749.02' BM Description Center of sanitary manhole

A. Regional Floodplain elevation 749.9

B. Required Elevation of fill (A + 1 ft) 752.3'

Side (Circle one) N **(S)** E W

C. Lowest ground elevation along property line, in affected area 749.2

D. Depth of Fill required (B – C) 2.1

E. Length of horizontal slope using 3:1 slope (D x 3) N/A

F. Width of Swale (if proposed) N/A

G. Side yard setback proposed for structure 13'11"

H. Total horizontal fill proposed (G – E – F) 5'-0"

Retaining Wall

Side (Circle one) N **(S)** E W

Total fill proposed (from foundation to outer edge of retaining wall) 5 ft

Will the retaining wall(s) meet the 75' required setback from the Ordinary High Water Mark?

YES _____ NO X

If no, variance requested for retaining wall? 16 ft

List any measures proposed to prevent run-off onto neighboring properties:

 X Swale _____ Drain Tile X Downspouts to lake/ditch

_____ Other:

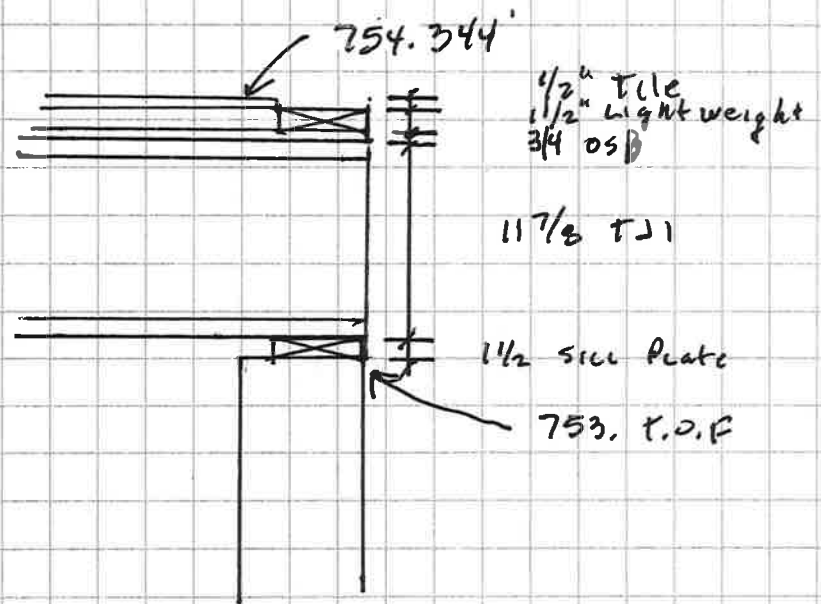
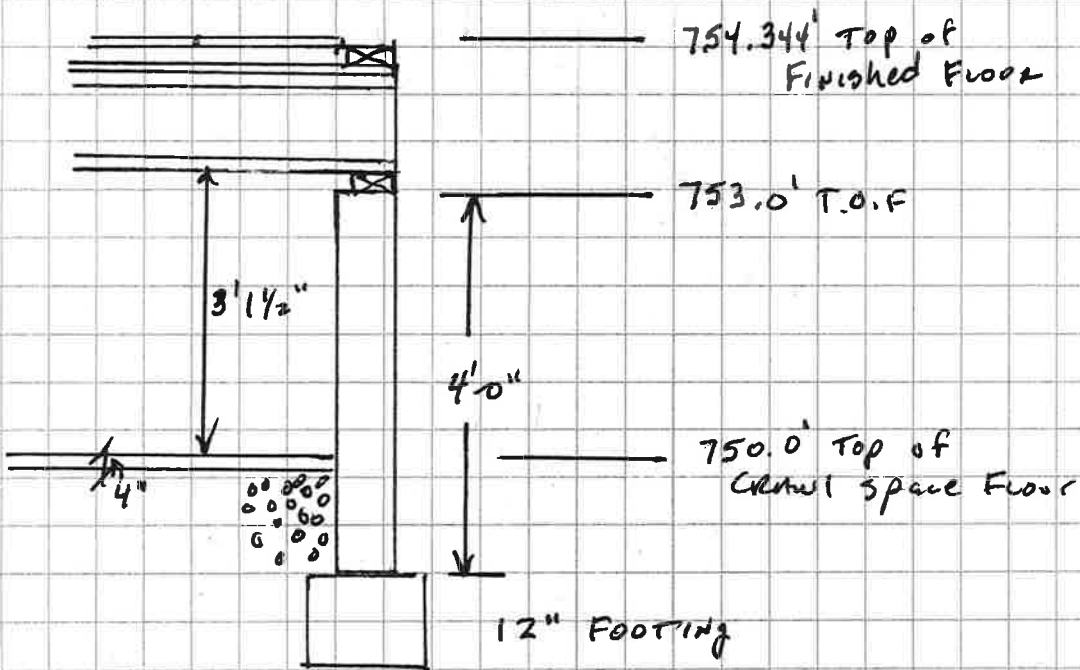

1/2" = 1'

House Section

OVERHEAD DOOR OPENING
 IS 6' LOWER THAN TOP OF FOUNDATION

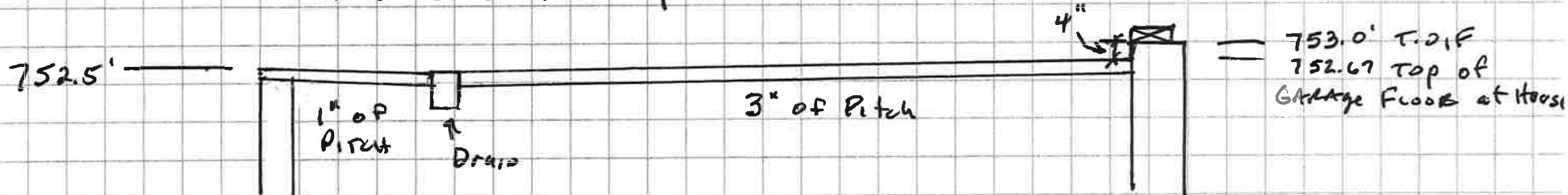

Garage Section

Gary + Beth Goldberg
 3693 Shangri-La Point Rd
 Oshkosh

GARY & Beth Goldberg
3693 Shangri-La Point
OSHKOSH



1" = 40'

3681 Shangri-La Point

3693 Shangri-La Point

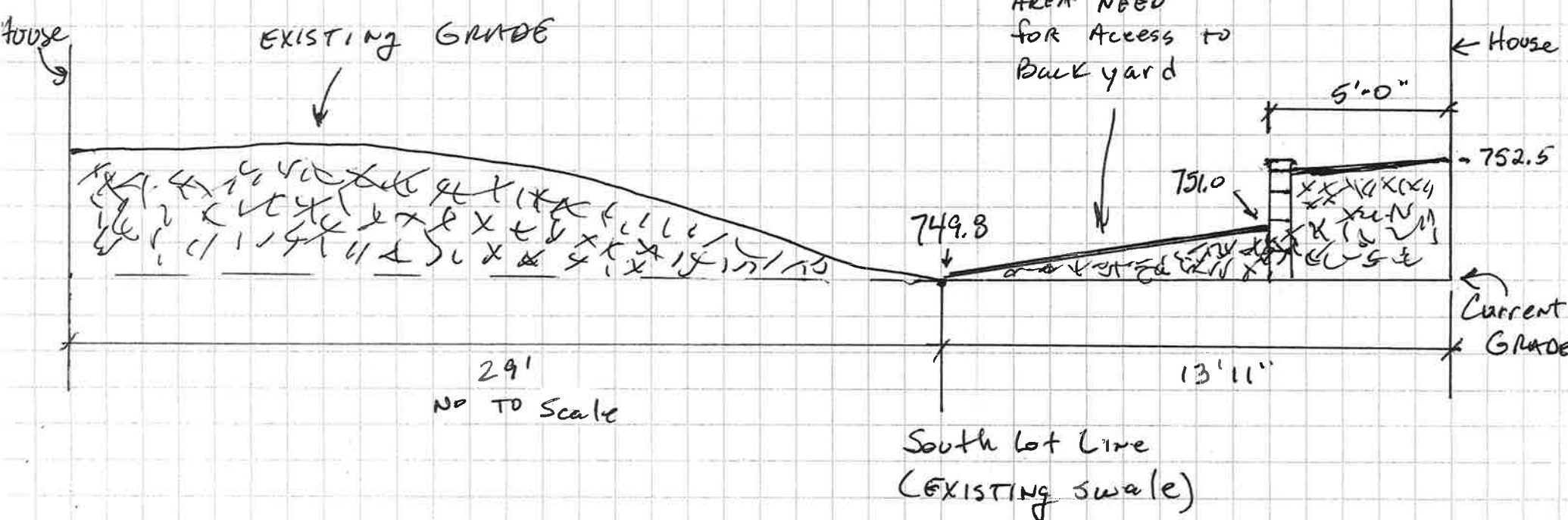



3681 Shangri-La

1

3693 - Shangri-La



3693 Shangri-la 1

3681 Shangri-la

18-2335

3693 Shangri-La Point Rd

J
Gary Goldberg REV



Site Map

Legend

- Address Marker
- Tax Parcel
- Section Number
- Conveyance Divisions
- Conveyance Types
- Certified Survey
- Condominium
- Assessor Plat
- Subdivision
- Plat of Survey
- Lakes

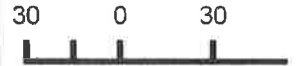

1 Inch = 60 Feet



WINGS Project Disclaimer
 This data was created for use by the Winnebago County Geographic Information System project. Any other use/application of this information is the responsibility of the user and such use/application is at their own risk. Winnebago County disclaims all liability regarding fitness of the information for any use other than Winnebago County business. *Data for this map copyrighted December 31 2006*

Jun 28, 2016 @ 10:32 AM

PLAT OF SURVEY

ALL OF LOT 2 OF "SHANGRI-LA POINT PLAT", IN SECTION 5, TOWNSHIP 18 NORTH, RANGE 16 EAST, TOWN OF OSHKOSH, WINNEBAGO COUNTY, WISCONSIN.

SURVEY FOR:
GARY GOLDBERG
978 BUFFALO RIDGE RD.
CASTLE ROCK, CO 80108



BEARINGS ARE REFERENCED TO THE
WINNEBAGO COUNTY COORDINATE SYSTEM

Scale 1 inch = 30 feet

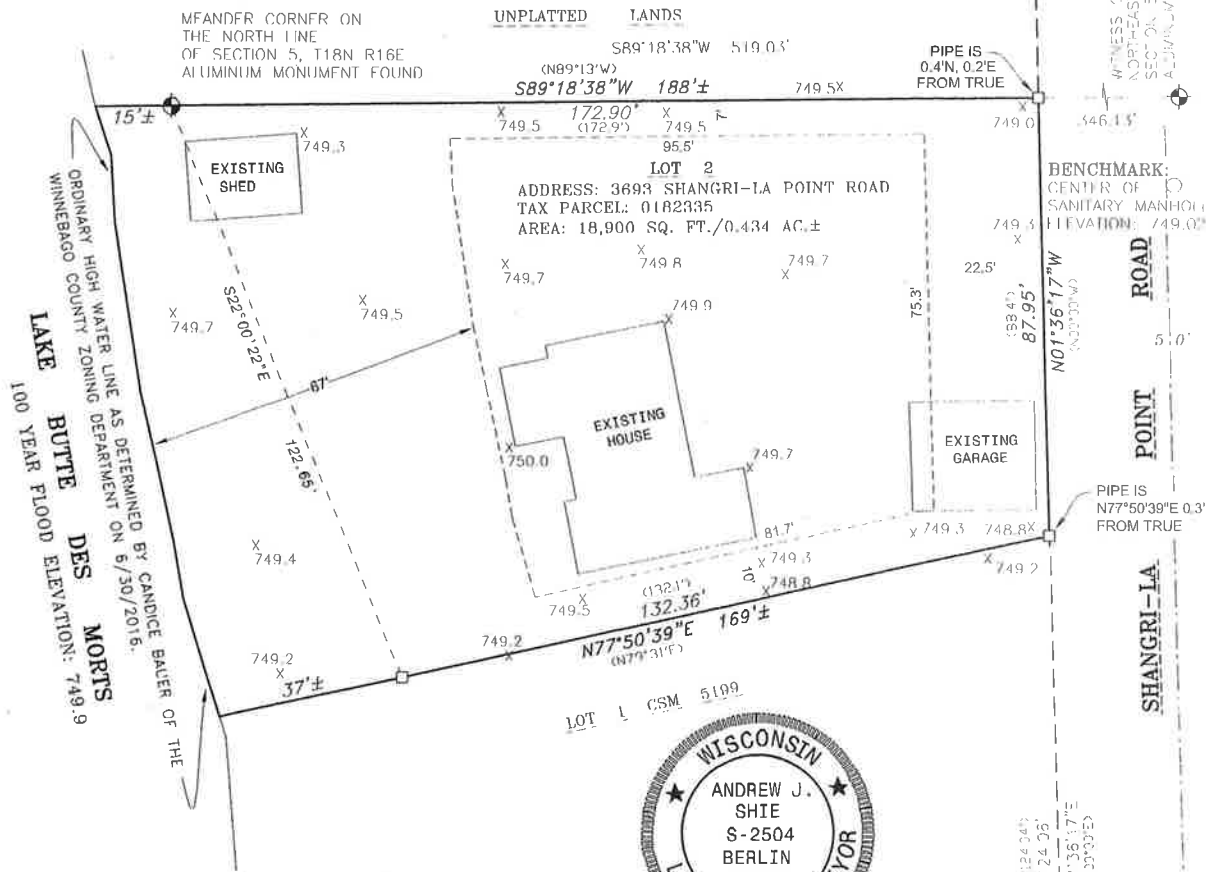

LEGEND

- 1-1/4" O.D. IRON PIPE FOUND
- ⊕ GOVERNMENT CORNER
- SANITARY MANHOLE
- X 749.3 EXISTING SPOT ELEVATION
- () RECORDED AS

I, Andrew J. Shie, Wisconsin Professional Land Surveyor, hereby certify that I have fully complied with A-E7 of the Wisconsin State Statutes, and that I have surveyed and mapped all boundaries shown on this map to the best of my knowledge and belief.

Andrew J. Shie

7/11/2016

Andrew J. Shie
Wisconsin Professional Land Surveyor S-2504

Date



**FOX VALLEY
LAND SURVEYING**

2909 W TILLMAN ST.
APPLETON, WI 54914
(920) 410-3379
(920) 474-5025
mail@foxvalleylandsurveying.com
foxvalleylandsurveying.com

PROJECT NO. 181605-1

NOTE:
SETBACK INFORMATION AS PROVIDED BY WINNEBAGO COUNTY ZONING DEPARTMENT.
-67' FOR HOME, DECK & PATIO FROM THE ORDINARY HIGH WATER LINE
-22.5' FOR HOME & GARAGE FROM THE ROAD R/W LINE
-7' ONE SIDE & 10' OTHER SIDE FOR HOME & GARAGE FROM SIDE YARD
-IT IS THE RESPONSIBILITY OF THE BUILDER TO VERIFY SETBACKS PRIOR TO BUILDING. FOX VALLEY LAND SURVEYING WILL NOT BE HELD RESPONSIBLE FOR ANY SETBACK INFORMATION SHOWN.

SITE PLAN

ALL OF LOT 2 OF "SHANGRI-LA POINT PLAT", IN SECTION 5, TOWNSHIP 18 NORTH, RANGE 16 EAST, TOWN OF OSHKOSH, WINNEBAGO COUNTY, WISCONSIN.

TAX PARCEL 0182335
 ADDRESS: 3693 SHANGRI-LA POINT RD.
 TOTAL LOT AREA: 18,900 SQ. FT. ±

EXISTING IMPERVIOUS AREAS TO BE REMOVED:
 HOUSE: 1,450 SQ. FT.
 GARAGE: 540 SQ. FT.
 SHED WITH CONCRETE & OVERHANG: 785 SQ. FT.

PROPOSED IMPERVIOUS AREAS:
 HOUSE & GARAGE: 3,875 SQ. FT.
 OVERHANGS, PORCH AND PATIO AREAS: 1600 SQ. FT.
 DRIVEWAY: 600 SQ. FT.
 SIDEWALK: 425 SQ. FT.
 TOTAL IMPERVIOUS AREA: 6,500 SQ. FT.



DRAWING FOR:
 GARY GOLDBERG
 978 BUFFALO RIDGE RD.
 CASTLE ROCK, CO 80108

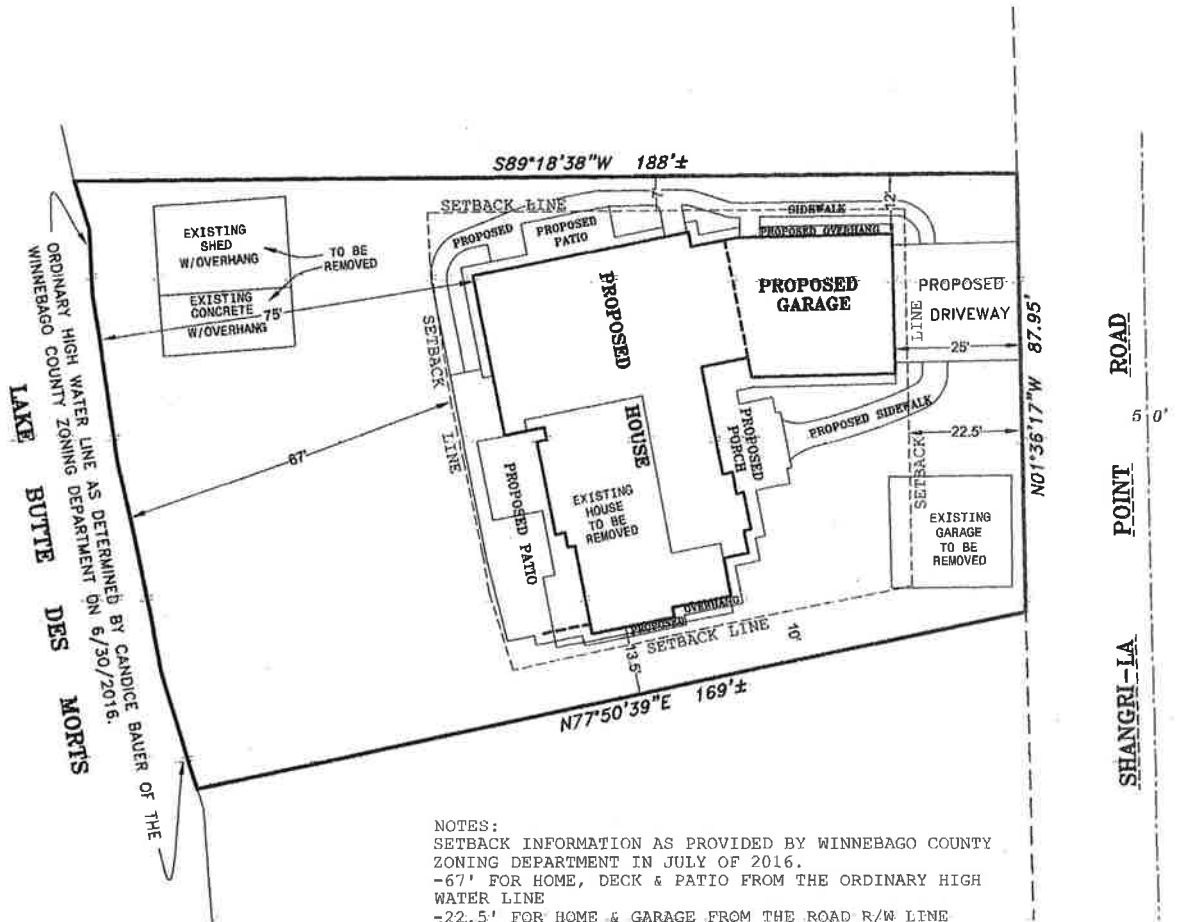
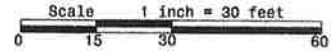

NOTES:
 SETBACK INFORMATION AS PROVIDED BY WINNEBAGO COUNTY ZONING DEPARTMENT IN JULY OF 2016.
 -67' FOR HOME, DECK & PATIO FROM THE ORDINARY HIGH WATER LINE
 -22.5' FOR HOME & GARAGE FROM THE ROAD R/W LINE
 -7' ONE SIDE & 10' OTHER SIDE FOR HOME & GARAGE FROM SIDE YARD

-PROPOSED ELEVATIONS PROVIDED BY SMITH BUILDERS ARE:
 -TOP OF CRAWL SPACE 750.33
 -TOP OF GARAGE FLOOR 752.5
 -TOP OF FOUNDATION 753.0

-PROPOSED IMPROVEMENTS AND LOCATIONS AS PROVIDED BY OTHERS.

-IT IS THE RESPONSIBILITY OF THE BUILDER TO VERIFY SETBACKS PRIOR TO BUILDING. FOX VALLEY LAND SURVEYING WILL NOT BE HELD RESPONSIBLE FOR ANY SETBACK INFORMATION SHOWN.

DATED: 1/12/2021



**FOX VALLEY
 LAND SURVEYING**
 4321 W. College Ave., Suite 200
 Appleton, WI 54914
 (920) 410-3379
 (920) 474-5025
 mail@foxvalleylandsurveying.com
 foxvalleylandsurveying.com

PROJECT NO. 181605-1

SITE NOTES

1. EXISTING LOTS 11 AND 12 ARE BOUND BY UNDEVELOPED LOTS 13, 14 AND 15.
2. VERIFY ALL LOT AND CORNER POINTS TO AVOID CONFLICTS WITH EXISTING ADJACENT LOTS AND WITH ALL CITY ZONING REGULATIONS AND DEVELOPMENT ORDINANCES.
3. PROPERTY BOUNDARIES AND DIMENSIONS SHOWN ARE BASED ON THE RECORD PLAT FOR SHANGRI LA POINT PLAT.
4. PROPERTY BOUNDARIES AND DIMENSIONS SHOWN ARE BASED ON THE RECORD PLAT FOR SHANGRI LA POINT PLAT.
5. PROPERTY BOUNDARIES AND DIMENSIONS SHOWN ARE BASED ON THE RECORD PLAT FOR SHANGRI LA POINT PLAT.
6. PROPERTY BOUNDARIES AND DIMENSIONS SHOWN ARE BASED ON THE RECORD PLAT FOR SHANGRI LA POINT PLAT.
7. PROPERTY BOUNDARIES AND DIMENSIONS SHOWN ARE BASED ON THE RECORD PLAT FOR SHANGRI LA POINT PLAT.
8. PROPERTY BOUNDARIES AND DIMENSIONS SHOWN ARE BASED ON THE RECORD PLAT FOR SHANGRI LA POINT PLAT.
9. PROPERTY BOUNDARIES AND DIMENSIONS SHOWN ARE BASED ON THE RECORD PLAT FOR SHANGRI LA POINT PLAT.
10. PROPERTY BOUNDARIES AND DIMENSIONS SHOWN ARE BASED ON THE RECORD PLAT FOR SHANGRI LA POINT PLAT.
11. VERIFY ALL LOT AND CORNER POINTS TO AVOID CONFLICTS WITH EXISTING ADJACENT LOTS AND WITH ALL CITY ZONING REGULATIONS AND DEVELOPMENT ORDINANCES.
12. VERIFY ALL LOT AND CORNER POINTS TO AVOID CONFLICTS WITH EXISTING ADJACENT LOTS AND WITH ALL CITY ZONING REGULATIONS AND DEVELOPMENT ORDINANCES.

LOT COVERAGE

Lot	Area (sq. ft.)	Percentage
LOT 1	1,200.00	20.00%
LOT 2	1,200.00	20.00%
LOT 3	1,200.00	20.00%
LOT 4	1,200.00	20.00%
LOT 5	1,200.00	20.00%
TOTAL LOT AREA	6,000.00	100%

SITE LEGEND



SITE PLAN

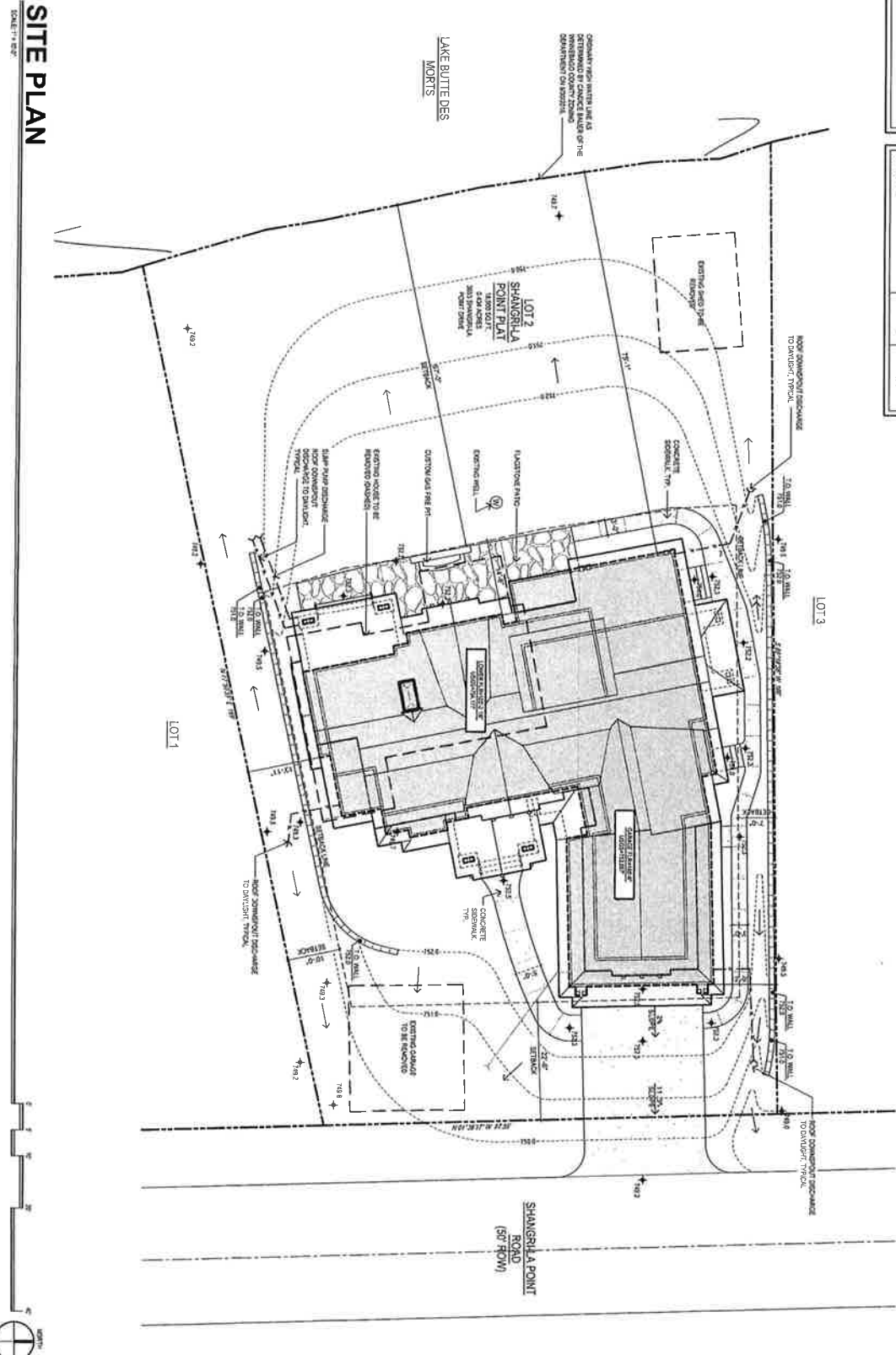

Application #21-VA-5580

Date of Hearing:
March 30, 2021

Owner(s):
GOLDBERG REV TST, GARY J
GOLDBERG REV TST, BETH A

Subject Parcel(s):
0182335

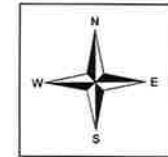

Winnebago County
WINGS Project

Scale
1 inch : 300 feet

County Zoning Districts

R-1	PDD	B-1
R-2	A-1	B-2
R-3	A-2	B-3
R-4	I-1	M-1
R-8	I-2	Town Zoning

City of Oshkosh Extraterritorial
Zoning Jurisdiction

Incorporated Area

